

2.2.2 MHC SERIES

Single acting, 350 bar



Capacity: 44, 68 and 116 kN at 350 bar
 Working pressure: 350 bar
 Single acting
 Temperature range: 6°C till 60°C

DESCRIPTION

These high quality pull cylinders features also a swivel plate which allows applications at non straight die surfaces. More capacity within the small dimensions due to higher operating pressure of 350 bar.

Ordering code: MHC-A/B/C

A= cylinder capacity in kN, being 50, 70 or 110.
 B= T-slot dimension "A" in mm, being 22, 28 or 36.
 C=distance H + F in mm. (H= backplate height)

Order Code Example: MHC 110/28/85.

This is a 116 kN cylinder with dimension H+F 85 mm and for a T-slot of 28 mm.

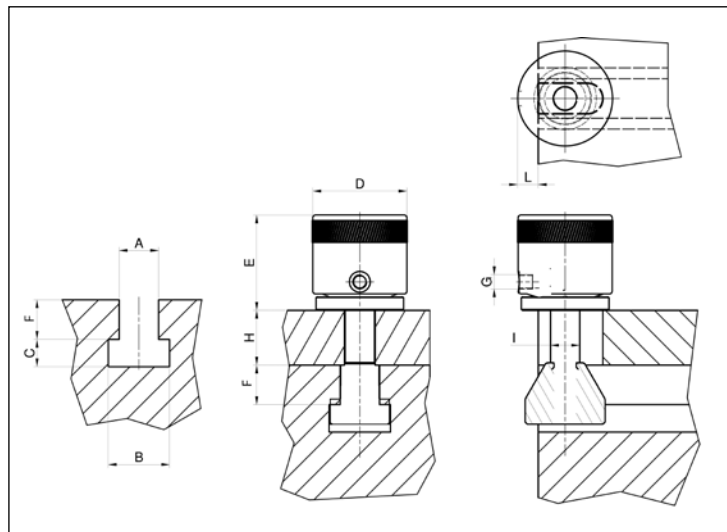

SELECTION CHART

EAS Model Number	Clamping force (kN)	Operating pressure (bar)	Stroke (mm)	Oil capacity (cm ³)	Max h+ d (mm)	Dimensions in mm								
						A.	B	C	F	D	E	G	I	Lmax
MHC50/22/..	44	350	12	15	120	22	37	16	*	62	73,5	G 1/4"	17,5	17
MHC70/22/..	68,7	350	12	23,5	150	22	37	16	*	70	77	G 1/4"	21,5	25
MHC70/28/..	68,7	350	12	23,5	150	28	46	20	*	70	77	G 1/4"	21,5	25
MHC110/28/..	116,1	350	12	39,8	200	28	46	20	*	86	85	G 1/4"	27	30
MHC110/36/..	116,1	350	12	39,8	200	26	56	25	*	86	85	G 1/4"	27	30