

**PSL-28-XX**

"A" = CLAMPHEIGHT 62 mm

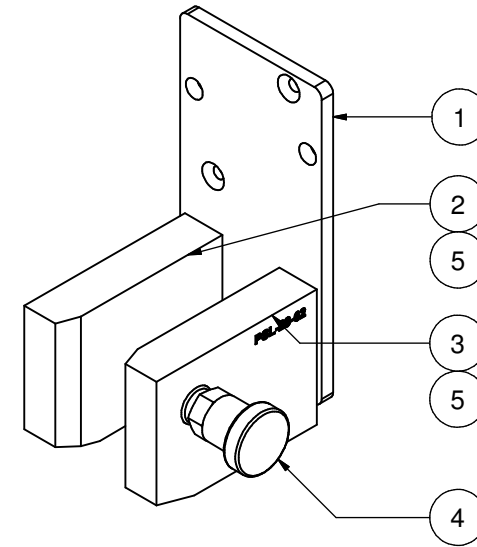

E0087	RELEASED	11/13
EASC	CHANGES	DATE

Parts List

ITEM	QTY	PART NUMBER	DESCRIPTION
1	1	FB378-111	BRACKET
2	1	REF6286-C (62)	ADAPTOR BLOCK
3	1	REF6285-C (62)	ADAPTOR BLOCK LOCK PIN
4	1	FB309-061	LOCK PIN
5	4	CBA821-028-1B	SCREW M8x20
6	2	CCA819.028-1A	SCREW M8x16 (MOUNT. MAT.)
7	1		PLASTIC BAG
8	1		CARTON
9	1	BSS 3874 D	CARTON LABEL

TOLERANCES ON DIMENSIONS UNLESS SPECIFIED ± MM[inch]					TOL. ON ANGLES UNLESS SPEC.	TOL. ON RADII UNLESS SPEC. ± MM[inch]			
SIZE	0.5-6 [.02-.24]	6-30 [.24-1.18]	30-120 [1.18-4.72]	120-315 [4.72-12.40]		315-1000 [12.40-39.37]	SIZE	0.5-3 [.02-.12]	3-6 [.12-.24]
TOL.	0.1 [.004]	0.2 [.008]	0.3 [.012]	0.5 [.02]	0.8 [.03]	TOL.	0.2 [.008]	0.5 [.02]	1 [.04]

SPECIFICATIONS		DIMENSIONS IN BRACKETS ARE IN [INCH]		
NO CHANGE, NO PROGRESS		FINISH UNLESS SPECIFIED		
WEIGHT: ± 2,159 kg		3,2 $\sqrt{Ra\mu m}$ [Raμ]		www.EASchangesystems.com
ALL ANGULAR DIMENSIONS ARE ± 1° UNLESS SPECIFIED		SCALE 1:1		DESCRIPTION <b>PARKSTATION 28</b>
GROUP TECH. CODES	C.	DO NOT SCALE DRAWING	DR breep	DRAWING NO. PSL28-62
	M.		CH.	Rev 9/02
				A3