

PSL22-1-84

"A" = CLAMPHEIGHT

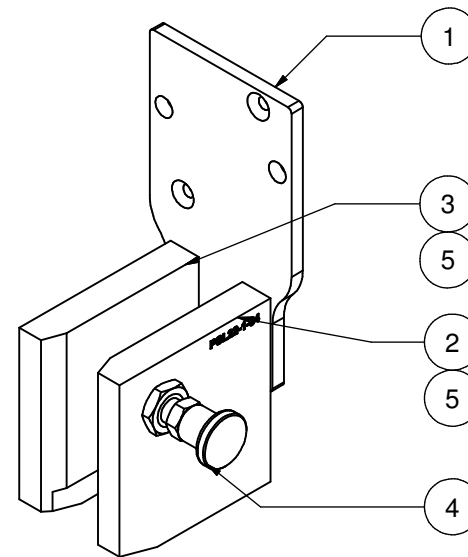

PDP20004	RELEASED	06/20
EASC	CHANGES	DATE

Parts List

ITEM	QTY	PART NUMBER	DESCRIPTION
1	1	FB377-111	BRACKET
2	1	REF6293-C (84)	ADAPTOR PLATE LOCKPIN
3	1	REF6294-C-(84)	ADAPTOR PLATE
4	1	FB308-061	LOCK PIN
5	4	CBA617.028-1B	SCREW M6x16
6	2	CCA819.028-1A	SCREW M8x16 (MOUNT. MAT.)
7	1		PLASTIC BAG
8	1		CARTON
9	1	BSS 3874 D	CARTON LABEL

TOLERANCES ON DIMENSIONS UNLESS SPECIFIED ± MM[inch]						TOL. ON ANGLES UNLESS SPEC.	TOL. ON RADII UNLESS SPEC. ± MM[inch]			
SIZE	0.5-6 [.02-.24]	6-30 [.24-1.18]	30-120 [1.18-4.72]	120-315 [4.72-12.40]	315-1000 [12.40-39.37]		SIZE	0.5-3 [.02-.12]	3-6 [.12-.24]	6-30 [.24-1.18]
TOL.	0.1 [.004]	0.2 [.008]	0.3 [.012]	0.5 [.02]	0.8 [.03]	± 1°	TOL.	0.2 [.008]	0.5 [.02]	1 [.04]

SPECIFICATIONS		DIMENSIONS IN BRACKETS ARE IN [INCH]				
NO CHANGE, NO PROGRESS		FINISH UNLESS SPECIFIED				
WEIGHT: ± 1,948 kg		3,2 $\sqrt{Ra\mu m [Ra\mu]}$			DESCRIPTION	
ALL ANGULAR DIMENSIONS ARE ± 1° UNLESS SPECIFIED		SCALE 1:1.5			PARKSTATION ECA100-22 PSL22-1 (84)	
GROUP TECH. CODES	C. M.	DO NOT SCALE DRAWING	DR. breep CH.	DATE 9-12-2020	DRAWING NO. PSL22-1 (84)	Rev 9/02 A3