

**PSL-28-XX**

"A" = CLAMPHEIGHT 85 mm

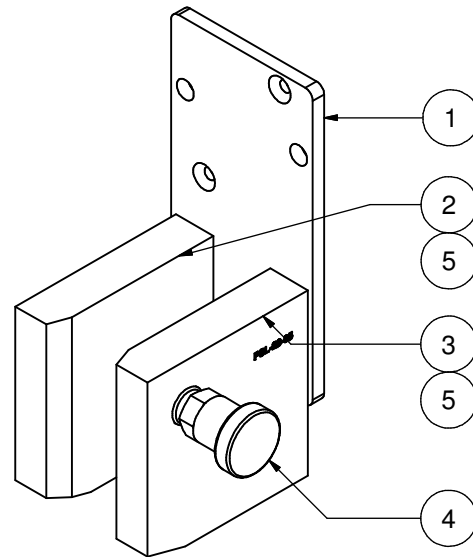

E0087	RELEASED	11/13
EASC	CHANGES	DATE

Parts List											
ITEM	QTY	PART NUMBER				DESCRIPTION					
1	1	FB378-111				BRACKET					
2	1	REF6286-C (85)				ADAPTOR BLOCK					
3	1	REF6285-C (85)				ADAPTOR BLOCK LOCK PIN					
4	1	FB309-061				LOCK PIN					
5	4	CBA821-028-1B				SCREW M8x20					
6	2	CCA819.028-1A				SCREW M8x16 (MOUNT. MAT.)					
7	1					PLASTIC BAG					
8	1					CARTON					
9	1	BSS 3874 D				CARTON LABEL					
TOLERANCES ON DIMENSIONS UNLESS SPECIFIED ± MM[inch]							TOL. ON ANGLES UNLESS SPEC.	TOL. ON RADII UNLESS SPEC. ± MM[inch]			
SIZE	0.5-6 [.02-.24]	6-30 [.24-1.18]	30-120 [1.18-4.72]	120-315 [4.72-12.40]	315-1000 [12.40-39.37]		SIZE	0.5-3 [.02-.12]	3-6 [.12-.24]	6-30 [.24-1.18]	
TOL.	0.1 [.004]	0.2 [.008]	0.3 [.012]	0.5 [.02]	0.8 [.03]	± 1°	TOL.	0.2 [.008]	0.5 [.02]	1 [.04]	
SPECIFICATIONS					DIMENSIONS IN BRACKETS ARE IN [INCH]			 DE HOOGE HOEK 19A 3927 GG RENSWOUDE HOLLAND POSTBOX 460 MILWAUKEE WI 53201-0460 USA DESCRIPTION <b>PARKSTATION 28</b>			
WEIGHT: ± 2,767 kg					EAS a global company						
ALL ANGULAR DIMENSIONS ARE ± 1° UNLESS SPECIFIED					FINISH UNLESS SPECIFIED 3,2 $\sqrt{Ra\mu m}$ [Raμ]						
GROUP TECH. CODES	C.				DO NOT SCALE DRAWING	DR breep	DATE 29-9-2015	DRAWING NO. PSL-28 (85)			
	M.					CH.	DATE	Rev	9/02		
									A3		