

**PSL-28-XX**

"A" = CLAMPHEIGHT 70 mm

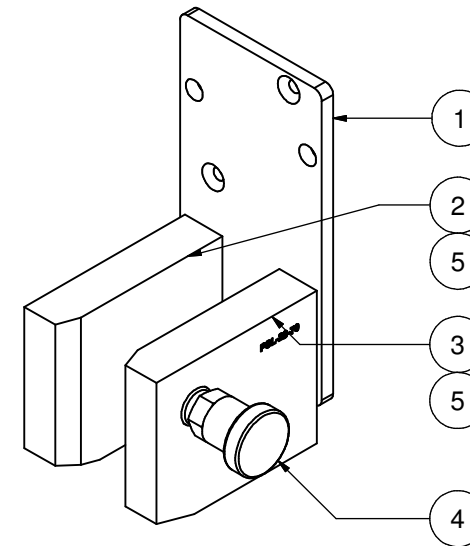

Parts List

ITEM	QTY	PART NUMBER	DESCRIPTION
1	1	FB378-111	BRACKET
2	1	REF6286-C (70)	ADAPTOR BLOCK
3	1	REF6285-C (70)	ADAPTOR BLOCK LOCK PIN
4	1	FB309-061	LOCK PIN
5	4	CBA821-028-1B	SCREW M8x20
6	2	CCA819.028-1A	SCREW M8x16 (MOUNT. MAT.)
7	1		PLASTIC BAG
8	1		CARTON
9	1	BSS 3874 D	CARTON LABEL

TOLERANCES ON DIMENSIONS UNLESS SPECIFIED ± MM[inch]						TOL. ON ANGLES UNLESS SPEC.	TOL. ON RADII UNLESS SPEC. ± MM[inch]			
SIZE	0.5-6 [.02-.24]	6-30 [.24-1.18]	30-120 [1.18-4.72]	120-315 [4.72-12.40]	315-1000 [12.40-39.37]		SIZE	0.5-3 [.02-.12]	3-6 [.12-.24]	6-30 [.24-1.18]
TOL.	0.1 [.004]	0.2 [.008]	0.3 [.012]	0.5 [.02]	0.8 [.03]	± 1°	TOL.	0.2 [.008]	0.5 [.02]	1 [.04]

SPECIFICATIONS		DIMENSIONS IN BRACKETS ARE IN [INCH]			
NO CHANGE, NO PROGRESS		FINISH UNLESS SPECIFIED			
WEIGHT: ± 2,371 kg		3,2 $\sqrt{Ra\mu m}$ [Raμ]		DESCRIPTION	
ALL ANGULAR DIMENSIONS ARE ± 1° UNLESS SPECIFIED		SCALE 1:1,5		<b>PARKSTATION 28</b> <b>PSL-28 (70)</b>	
GROUP TECH. CODES	C. M.	DO NOT SCALE DRAWING	DR breep CH.	DATE 17-9-2018	DRAWING NO. PSL-28 (70) Rev
				DATE	9/02 A3