

SCREWS M16, DIN912 Quality: 12.9 (2x)
TORQUE: 240 260 Nm

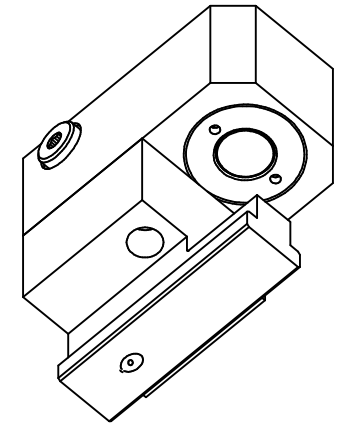
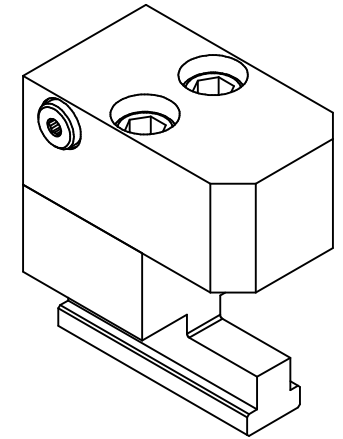
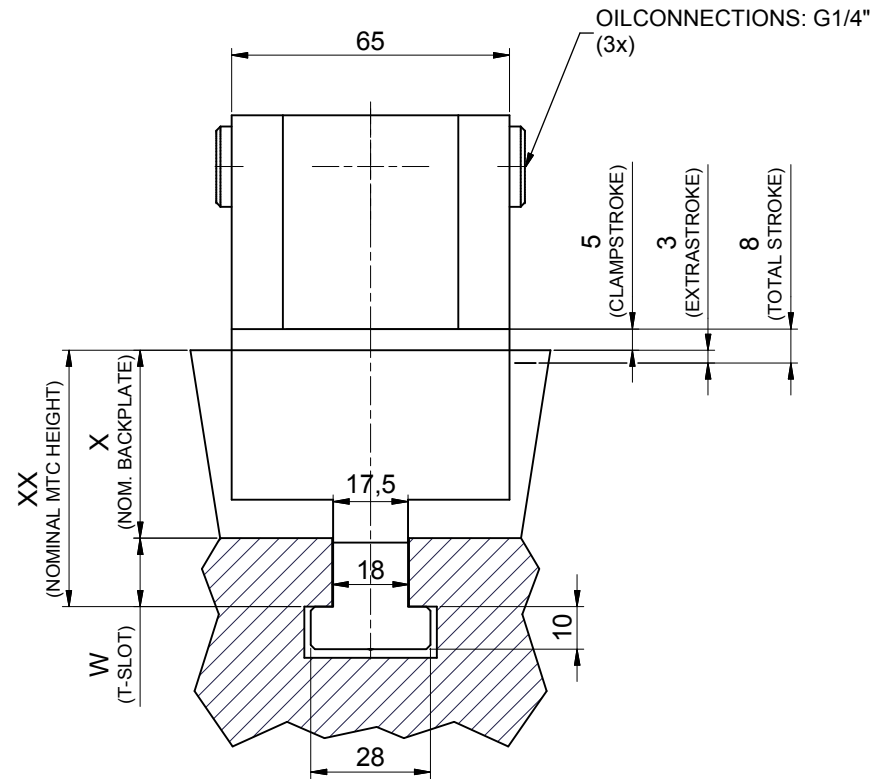

MTC45-18-XX:

CLAMPFORCE at 350 bar = 43.7 kN
TOTAL STROKE = 8 mm

Parts List

ITEM	QTY	PART NUMBER	DESCRIPTION
1	1	MTC45-18-XX	T-SLOT BODY
2	1	DQ1225-900 V	CYLINDER ASS'y
3	2	CCE1016.108-5C	WASHER-SPRING
4	2	CCA1633.028-1A	SCREW M16x50
5	1	CCA823-0285C	SET SCREW M8x20

TOLERANCES ON DIMENSIONS UNLESS SPECIFIED ± MM[inch]						TOL. ON ANGLES UNLESS SPEC.	TOL. ON RADII UNLESS SPEC. ± MM[inch]			
SIZE	0.5-6 [.02-.24]	6-30 [.24-1.18]	30-120 [1.18-4.72]	120-315 [4.72-12.40]	315-1000 [12.40-39.37]		SIZE	0.5-3 [.02-.12]	3-6 [.12-.24]	6-30 [.24-1.18]
TOL.	0.1 [.004]	0.2 [.008]	0.3 [.012]	0.5 [.02]	0.8 [.03]	± 1°	TOL.	0.2 [.008]	0.5 [.02]	1 [.04]
SPECIFICATIONS						DIMENSIONS IN BRACKETS ARE IN [INCH]				
WEIGHT: ± 4.229 kg						NO CHANGE, NO PROGRESS				
						3,2 $\sqrt{Ra_{\mu m}}$ [Ra $_{\mu}$]				
ALL ANGULAR DIMENSIONS ARE ± 1° UNLESS SPECIFIED						SCALE 1 : 1,25		 www.EASchangesystems.com DESCRIPTION CLAMP CYLINDER ASS'y		
GROUP TECH. CODES	C.		DO NOT SCALE DRAWING	DR. Yue	DATE 2020/5/15	DRAWING NO. MTC45-18-XX				
	M.			CH.	DATE	Rev 9/02				
									A3	