

SCREWS M16, DIN912 Quality: 12.9 (2x)
TORQUE: 240 260 Nm

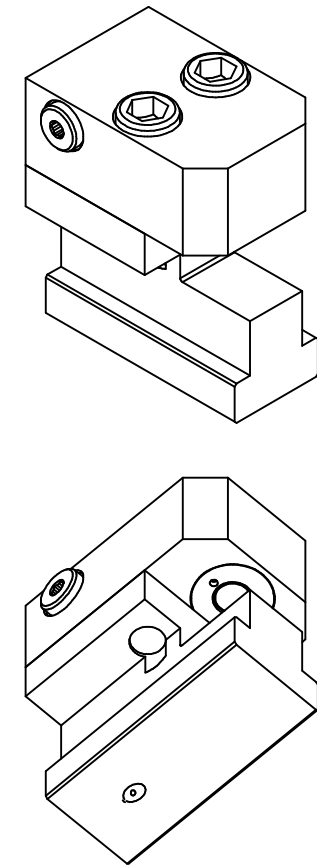
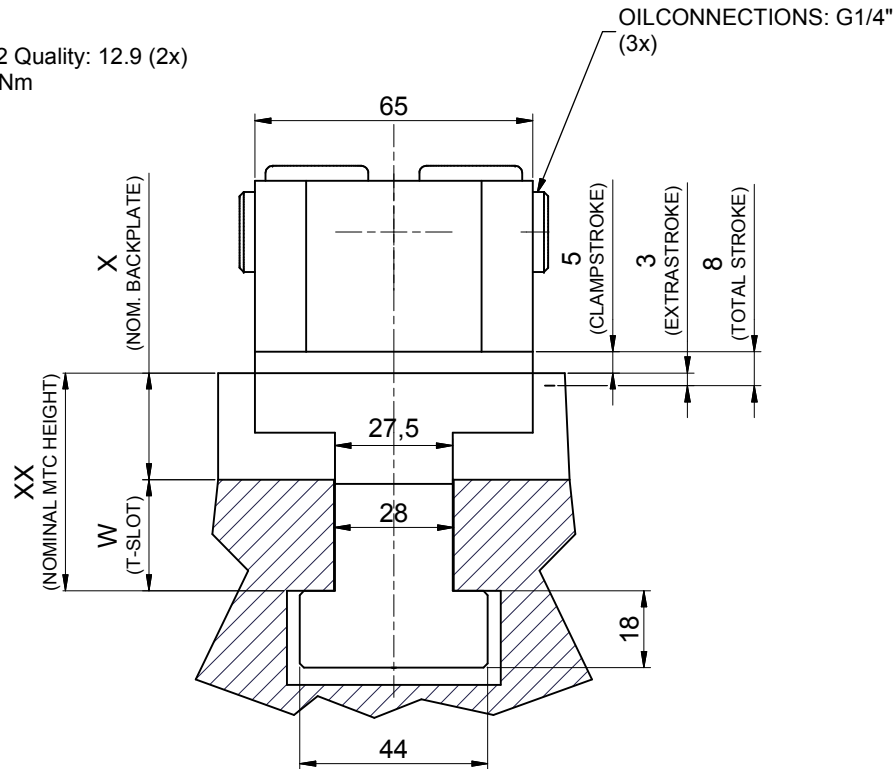

MTC15-28-XX:

CLAMPFORCE at 350 bar = 15.6 kN
TOTAL STROKE = 8 mm

Parts List

ITEM	QTY	PART NUMBER	DESCRIPTION
1	1	MTC15-28-XX	T-SLOT BODY
2	1	DQ1215-900 V	CYLINDER ASSY
3	2	CCE1016.108-5C	WASHER-SPRING
4	1	CCA823-0285C	SET SCREW M8x20
5	2	CCA1631.028-1A	SCREW M16x45

TOLERANCES ON DIMENSIONS UNLESS SPECIFIED ± MM[inch]						TOL. ON ANGLES UNLESS SPEC.	TOL. ON RADII UNLESS SPEC. ± MM[inch]			
SIZE	0.5-6 [.02-.24]	6-30 [.24-1.18]	30-120 [1.18-4.72]	120-315 [4.72-12.40]	315-1000 [12.40-39.37]		SIZE	0.5-3 [.02-.12]	3-6 [.12-.24]	6-30 [.24-1.18]
TOL.	0.1 [.004]	0.2 [.008]	0.3 [.012]	0.5 [.02]	0.8 [.03]	± 1°	TOL.	0.2 [.008]	0.5 [.02]	1 [.04]
SPECIFICATIONS						DIMENSIONS IN BRACKETS ARE IN [INCH]				
NO CHANGE, NO PROGRESS						FINISH UNLESS SPECIFIED				
WEIGHT: ± 3.682 kg						3,2 $\sqrt{Ra_{\mu m}}$ [Ra μ]			www.EASchangesystems.com	
ALL ANGULAR DIMENSIONS ARE ± 1° UNLESS SPECIFIED						SCALE 1 : 1,25			DESCRIPTION CLAMP CYLINDER MTC15 ASSY	
GROUP TECH. CODES	C.			DO NOT SCALE DRAWING	DR. Yue	DATE 2020/5/13	DRAWING NO. MTC15-28-XX		Rev	9/02
	M.				CH.	DATE				A3