

SCREWS M16, DIN912 Quality: 12.9 (2x)  
TORQUE: 240 .... 260 Nm

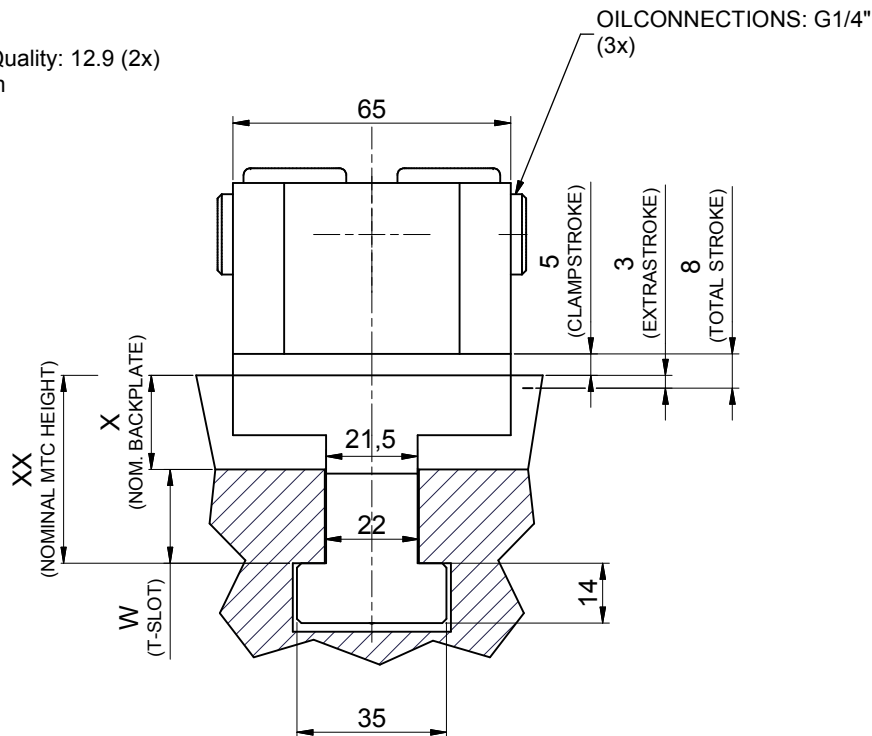

OILCONNECTIONS: G1/4"  
(3x)

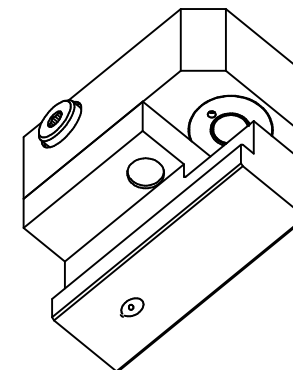
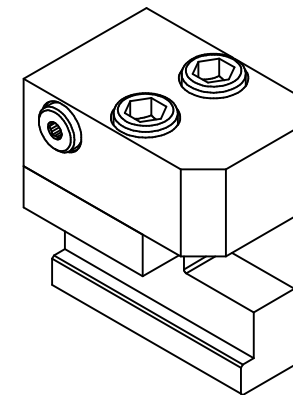

**MTC15-22-XX:**

**CLAMPFORCE at 350 bar = 15.6 kN**  
**TOTAL STROKE = 8 mm**

**Parts List**

ITEM	QTY	PART NUMBER	DESCRIPTION
1	1	DQ1276-190-44	T-SLOT BODY
2	1	DQ1215-900 V	CYLINDER ASSY
3	2	CCE1016.108-5C	WASHER-SPRING
4	1	CCA823-0285C	SET SCREW M8x20
5	2	CCA1631.028-1A	SCREW M16x45

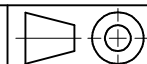
TOLERANCES ON DIMENSIONS UNLESS SPECIFIED ± MM[inch]						TOL. ON ANGLES UNLESS SPEC.	TOL. ON RADII UNLESS SPEC. ± MM[inch]				
SIZE	0.5-6 [.02-.24]	6-30 [.24-1.18]	30-120 [1.18-4.72]	120-315 [4.72-12.40]	315-1000 [12.40-39.37]		SIZE	0.5-3 [.02-.12]	3-6 [.12-.24]	6-30 [.24-1.18]	
TOL.	0.1 [.004]	0.2 [.008]	0.3 [.012]	0.5 [.02]	0.8 [.03]	± 1°	TOL.	0.2 [.008]	0.5 [.02]	1 [.04]	
SPECIFICATIONS						DIMENSIONS IN BRACKETS ARE IN [INCH]			 www.EASchangesystems.com		
NO CHANGE, NO PROGRESS						FINISH UNLESS SPECIFIED					
WEIGHT: ± 3.196 kg						3,2 $\sqrt{Ra_{\mu m}}$ [Ra $_{\mu}$ ]					
ALL ANGULAR DIMENSIONS ARE ± 1° UNLESS SPECIFIED						SCALE 1 : 1,25				DESCRIPTION <b>CLAMP CYLINDER MTC15 ASSY</b>	
GROUP TECH. CODES	C.			DO NOT SCALE DRAWING	DR. Yue	DATE 2020/5/12	DRAWING NO. MTC15-22-XX		Rev	9/02	
	M.				CH.	DATE				A3	