

**SECTION X-X ( 1 : 4 )**

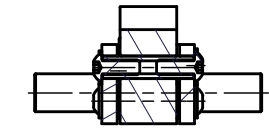

**SECTION Y-Y ( 1 : 4 )**

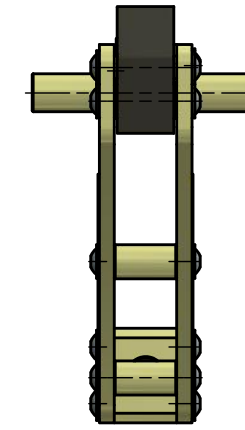
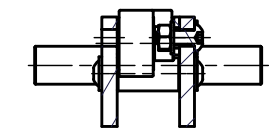

**SECTION Z-Z ( 1 : 4 )**

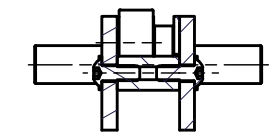

REVISION HISTORY EAS										
REV	ECO		DESCRIPTION			DATE	APPROVED			
-	E0105		RELEASED ACC. ECO			2017/11/24	welgravenj			
TOLERANCES ON DIMENSIONS UNLESS SPECIFIED ± MM[inch]						TOL. ON ANGLES UNLESS SPEC.	TOL. ON RADII UNLESS SPEC. ± MM[inch]			
SIZE	0.5-6 [.02-.24]	6-30 [.24-1.18]	30-120 [1.18-4.72]	120-315 [4.72-12.40]	315-1000 [12.40-39.37]		SIZE	0.5-3 [.02-.12]	3-6 [.12-.24]	6-30 [.24-1.18]
TOL.	0.1 [.004]	0.2 [.008]	0.3 [.012]	0.5 [.02]	0.8 [.03]	± 1'	TOL.	0.2 [.008]	0.5 [.02]	1 [.04]
SPECIFICATIONS					DIMENSIONS IN BRACKETS ARE IN [INCH]					
WEIGHT: ± 18,332 kg ALL ANGULAR DIMENSIONS ARE ± 1' UNLESS SPECIFIED					NO CHANGE, NO PROGRESS					
					3,2 $\sqrt{Ra\mu m [Ra\mu]}$ FINISH UNLESS SPECIFIED					
					SCALE 1:4					
GROUP TECH. CODES	C. M.	DO NOT SCALE DRAWING			DR. Yue CH.	DATE 10-2-2017 DATE				
DRAWING NO. FB900-950						DESCRIPTION EPR1-800 ASSY		www.EASchangesystems.com		
DRAWING NO. FB900-950						Rev 9/02		page 1 of 2 A3		

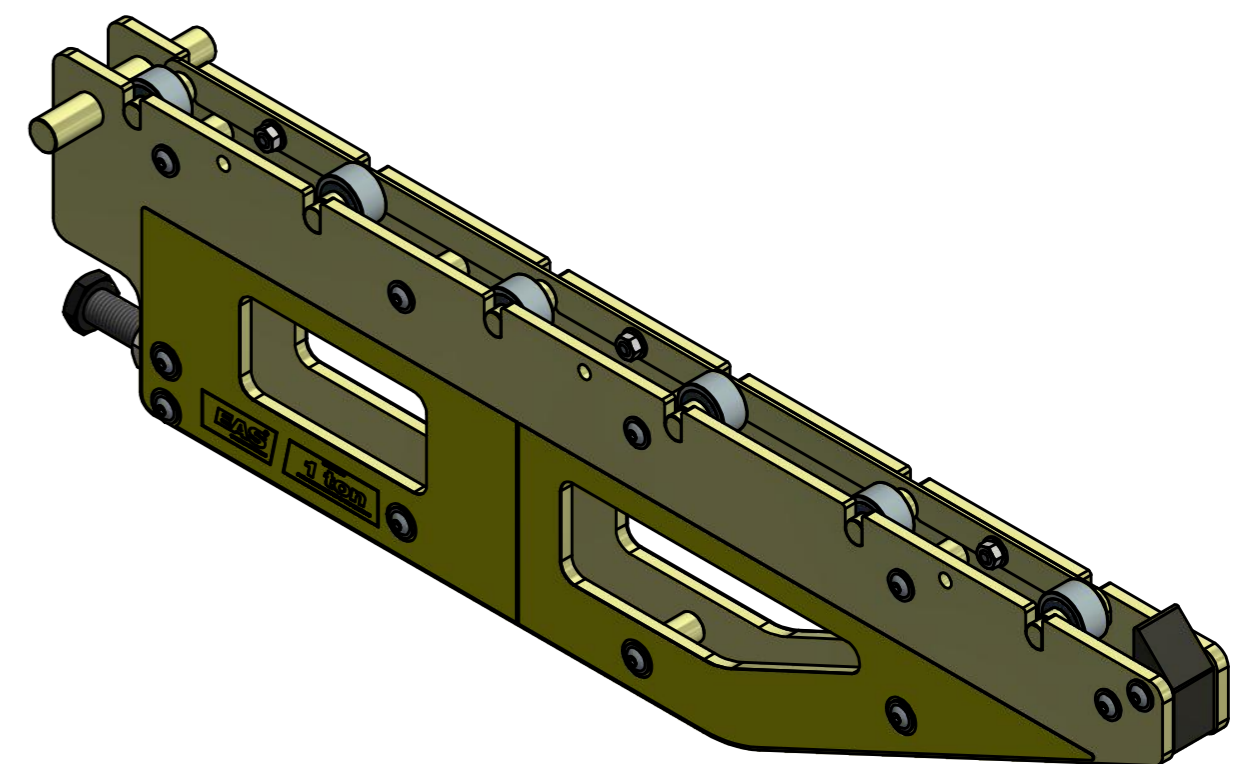
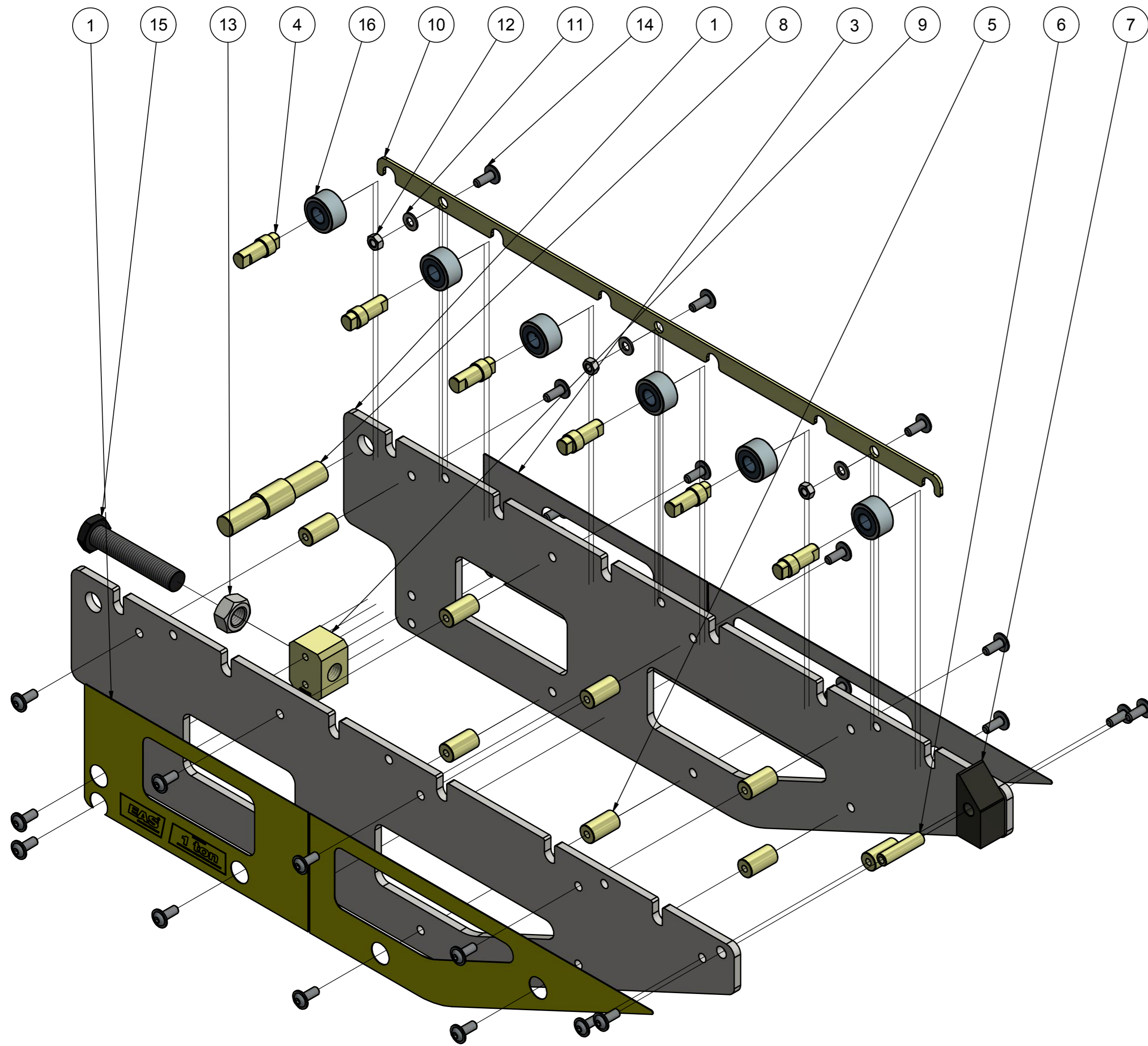

Parts List											
ITEM	QTY	PART NUMBER				DESCRIPTION					
1	2	FB901-101				CONSOLE PLATE					
2	1	FB902-026				DECAL 1-0,7mm PVC					
3	1	FB903-026				DECAL 2-0,7mm PVC					
4	6	FB627-104				ROLLER SHAFT					
5	8	FB751-186				SPACER					
6	1	FB755-104				SHAFT END STOP					
7	1	FB754-044				END STOP					
8	1	FB756-104				SUSPENSION SHAFT					
9	1	FB757-690				LEVELLING BLOCK					
10	1	FB662-101				MOUNTING PLATE					
11	3	CAE1080-1081A				WASHER M8					
12	3	CBB1080-1201D				NUT M8					
13	1	CBE1200.120-1D				NUT M20					
14	25	CCE820-028-9A				SCREW M8x20					
15	1	DQ1509.028				POSITIONING BOLT					
16	6	DQ1504-281				ROLLER					
TOLERANCES ON DIMENSIONS UNLESS SPECIFIED ± MM[inch]						TOL. ON ANGLES UNLESS SPEC.	TOL. ON RADII UNLESS SPEC. ± MM[inch]				
SIZE	0.5-6 [02-24]	6-30 [24-1.18]	30-120 [1.18-4.72]	120-315 [4.72-12.40]	315-1000 [12.40-39.37]	SIZE	0.5-3 [02-12]	3-6 [12-24]	6-30 [24-1.18]		
TOL.	0.1 [004]	0.2 [008]	0.3 [012]	0.5 [02]	0.8 [03]	± 1'	TOL.	0.2 [008]	0.5 [02]	1 [04]	
SPECIFICATIONS			DIMENSIONS IN BRACKETS ARE IN [INCH]								
WEIGHT: ± 18,332 kg			NO CHANGE, NO PROGRESS								
ALL ANGULAR DIMENSIONS ARE ± 1' UNLESS SPECIFIED			3,2 $\sqrt{Ra\mu m [Ra\mu]}$ FINISH UNLESS SPECIFIED								
SCALE 1:4			DO NOT SCALE DRAWING			DR. Yue		DATE 10-2-2017		DESCRIPTION EPR1-800 ASSY	
GROUP TECH. CODES	C.	M.	DO NOT SCALE DRAWING	DR. CH.	Yue	DATE	10-2-2017	DRAWING NO. FB900-950	Rev	9/02	
										page 2 of 2	