

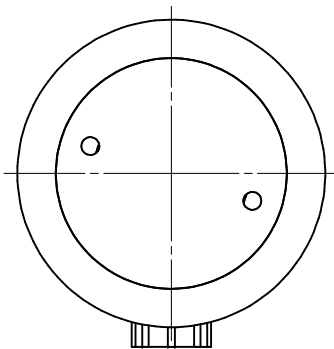

ECA-60-22-XX:

**CLAMPFORCE at 350 bar = 57,0 kN
TOTAL STROKE = 8 mm**

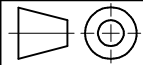

TOLERANCES ON DIMENSIONS UNLESS SPECIFIED ± MM[inch]						TOL. ON ANGLES UNLESS SPEC.	TOL. ON RADII UNLESS SPEC. ± MM[inch]			
SIZE	0.5-6 [.02-.24]	6-30 [.24-1.18]	30-120 [1.18-4.72]	120-315 [4.72-12.40]	315-1000 [12.40-39.37]		SIZE	0.5-3 [.02-.12]	3-6 [.12-.24]	6-30 [.24-1.18]
TOL.	0.1 [.004]	0.2 [.008]	0.3 [.012]	0.5 [.02]	0.8 [.03]	± 1°	TOL.	0.2 [.008]	0.5 [.02]	1 [.04]
SPECIFICATIONS						DIMENSIONS IN BRACKETS ARE IN [INCH]				 www.EASchangesystems.com
WEIGHT: ± 2.181 kg						NO CHANGE, NO PROGRESS				
						3,2 $\sqrt{Ra\mu}$ [Raμ]				
ALL ANGULAR DIMENSIONS ARE ± 1° UNLESS SPECIFIED						SCALE	1 : 1.25			
GROUP TECH. CODES	C.				DO NOT SCALE DRAWING	DR. CH.	Yue	DATE		2020/4/14
	M.							DATE		
						DESCRIPTION				Rev
						T-SLOT PULL CYLINDER ASS'Y				9/02
						DRAWING NO. ECA-60-22-XX				A3